

USER'S MANUAL

VUTR 202 VK EC
VUTR 202 VKS EC
VUTR 202 VEK EC
VUTR 202 VEKS EC

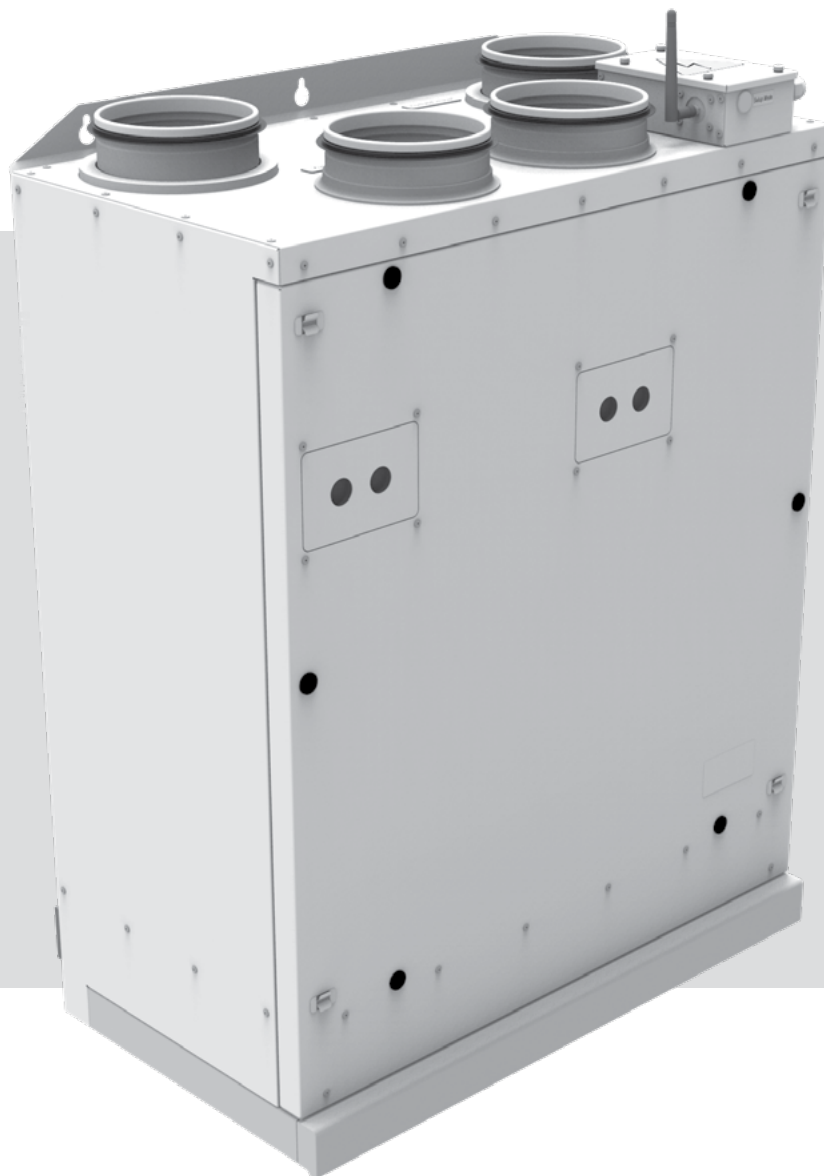

Single-room air handling unit with heat recovery

CONTENTS

Safety requirements.....	3
Purpose	5
Delivery set.....	5
Designation key.....	5
Technical data.....	6
Design and operating principle	8
Mounting and set-up.....	9
Connection to power mains	11
Technical maintenance.....	12
Troubleshooting.....	13
Storage and transportation regulations.....	14
Manufacturer's warranty	15
Certificate of acceptance.....	19
Seller information.....	19
Installation certificate.....	19
Warranty card.....	19

This user's manual is a main operating document intended for technical, maintenance, and operating staff.

The manual contains information about purpose, technical details, operating principle, design, and installation of the VUTR 202 V(E)K(S) EC unit and all its modifications.

Technical and maintenance staff must have theoretical and practical training in the field of ventilation systems and should be able to work in accordance with workplace safety rules as well as construction norms and standards applicable in the territory of the country.

SAFETY REQUIREMENTS

This unit is not intended for use by persons (including children) with reduced physical, sensory or mental capabilities, or lack of experience and knowledge, unless they have been given supervision or instruction concerning use of the unit by a person responsible for their safety. Children should be supervised to ensure that they do not play with the unit.

This appliance can be used by children aged from 8 years and above and persons with reduced physical, sensory or mental capabilities or lack of experience and knowledge if they have been given supervision or instruction concerning use of the appliance in a safe way and understand the hazards involved.

Cleaning and user maintenance shall not be done by children without supervision. Children shall not play with the appliance.

Connection to the mains must be made through a disconnecting device, which is integrated into the fixed wiring system in accordance with the wiring rules for design of electrical units, and has a contact separation in all poles that allows for full disconnection under overvoltage category III conditions.

Ensure that the unit is switched off from the supply mains before removing the guard.

Precautions must be taken to avoid the back-flow of gases into the room from the open flue of gas or other fuel-burning appliances.

The appliance may adversely affect the safe operation of appliances burning gas or other fuels (including those in other rooms) due to back flow of combustion gases. These gases can potentially result in carbon monoxide poisoning. After installation of the unit the operation of flued gas appliances should be tested by a competent person to ensure that back flow of combustion gases does not occur.

All operations described in this manual must be performed by qualified personnel only, properly trained and qualified to install, make electrical connections and maintain ventilation units.

Do not attempt to install the product, connect it to the mains, or perform maintenance yourself. This is unsafe and impossible without special knowledge.

Disconnect the power supply prior to any operations with the unit.

All user's manual requirements as well as the provisions of all the applicable local and national construction, electrical, and technical norms and standards must be observed when installing and operating the unit.

Disconnect the unit from the power supply prior to any connection, servicing, maintenance, and repair operations.

Connection of the unit to power mains is allowed by a qualified electrician with a work permit for the electric units up to 1000 V after careful reading of the present user's manual.

Check the unit for any visible damage of the impeller, the casing, and the grille before starting installation. The casing internals must be free of any foreign objects that can damage the impeller blades.

While mounting the unit, avoid compression of the casing! Deformation of the casing may result in motor jam and excessive noise.

Misuse of the unit and any unauthorised modifications are not allowed.

Do not expose the unit to adverse atmospheric agents (rain, sun, etc.).

Transported air must not contain any dust or other solid impurities, sticky substances, or fibrous materials.

Do not use the unit in a hazardous or explosive environment containing spirits, gasoline, insecticides, etc.

Do not close or block the intake or extract vents in order to ensure the efficient air flow.

Do not sit on the unit and do not put objects on it.

The information in this user's manual was correct at the time of the document's preparation.

The Company reserves the right to modify the technical characteristics, design, or configuration of its products at any time in order to incorporate the latest technological developments.

Never touch the unit with wet or damp hands.

Never touch the unit when barefoot.

BEFORE INSTALLING ADDITIONAL EXTERNAL DEVICES, READ THE RELEVANT USER MANUALS.



THE PRODUCT MUST BE DISPOSED SEPARATELY AT THE END OF ITS SERVICE LIFE.

DO NOT DISPOSE THE UNIT AS UNSORTED DOMESTIC WASTE.

PURPOSE

The unit is designed to ensure continuous mechanical air exchange in houses, offices, hotels, cafés, conference halls and other utility and public spaces as well as to recover the heat energy contained in the air extracted from the premises to warm up the filtered stream of supply air.

The unit is not intended for organizing ventilation in premises with high humidity.

Due to the ability to save heating energy by means of energy recovery, the unit is an important element of energy-efficient premises.

The unit is a component part and is not designed for stand-alone operation.

The unit is rated for continuous operation.

Transported air must not contain any flammable or explosive mixtures, evaporation of chemicals.

DELIVERY SET

Name	Number
Air handling uni	1 pc.
User's manual	1 pc.
User's manual (control panel)	1 pc.
Packing box	1 pc.

DESIGNATION KEY

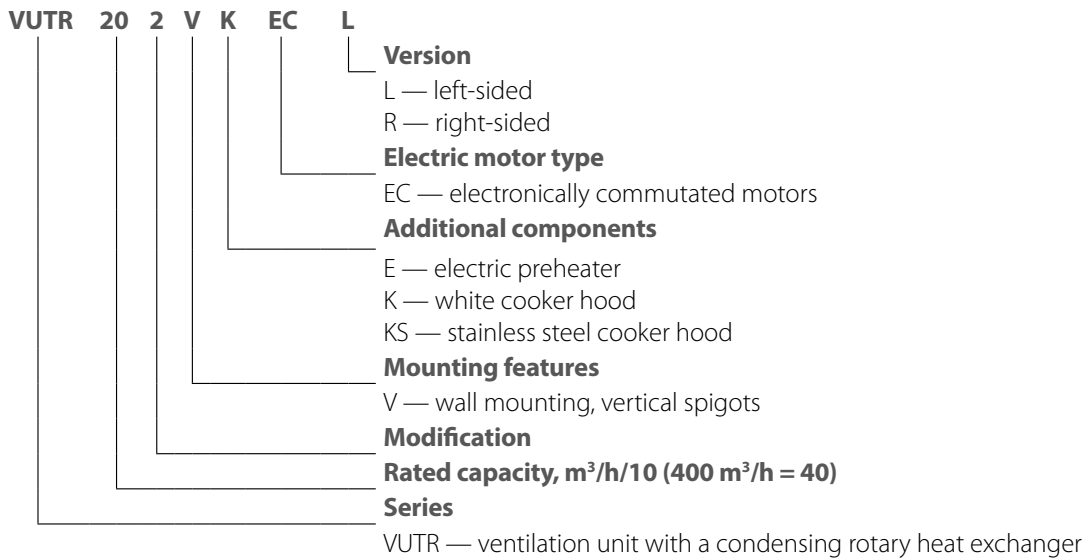

TECHNICAL DATA

The unit is designed for indoor application with the ambient temperature ranging from +1 °C up to +40 °C and relative humidity up to 60 % without condensation. In cold, damp rooms, there is a possibility of freezing or condensation inside and outside the casing.

In order to prevent condensation on the internal walls of the unit, it is necessary that the surface temperature of the casing is 2-3 °C above the dew point temperature of the transported air.

The unit should be operated continuously, and in cases where ventilation is not necessary, reduce the air flow of the fans to a minimum (20 %). This will ensure a favorable indoor climate and reduce the amount of condensation inside the unit, which can damage electronic components. Never use the unit for dehumidification, for example, of new buildings.

The unit is rated as a Class I electrical appliance.

Hazardous parts access and water ingress protection rating:

IP22 for the unit connected to the air ducts

IP44 for the unit motors

The unit design is constantly being improved, thus some models may be slightly different from those described in this manual.

TECHNICAL DATA

Parameter	VUTR 202 VK(S) EC	VUTR 202 VEK(S) EC
Power supply voltage, 50-60 Hz [V]	1~ 230	
Maximum unit power without electric heater [W]	187	
Maximum electric heater power [W]	–	700
Maximum unit power [W]	187	887
Maximum unit current without heaters [A]	1,38	
Maximum heaters current [A]	–	3,0
Maximum unit current [A]	1,38	4,38
Max. air flow [m ³ /h]	270	
Sound pressure level at 3 m [dBA]	33	
Maximum transported air temperature [°C]	-25...+40	
Casing material	Polymer-coated steel	
Insulation	Mineral wool [25 mm]	
Filter:	Extract air	G4
	Supply air	G4 (F7 optional)
Connected duct diameter [mm]	125	
Weight [kg]	51,6	52,6
Heat recovery efficiency [%]	87...93	
Heat exchanger type	Rotary	
Heat exchanger material	Aluminium	
Energy efficiency class	A	

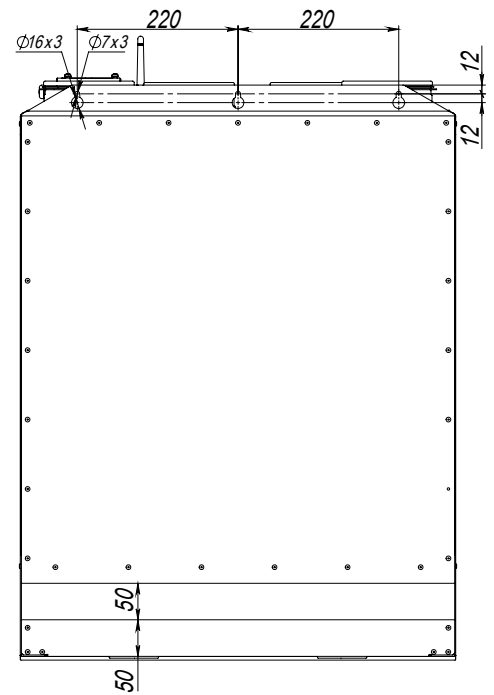
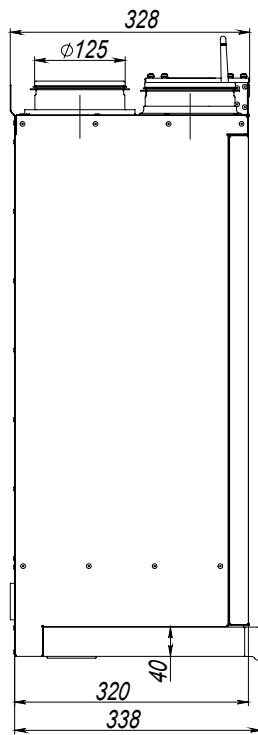
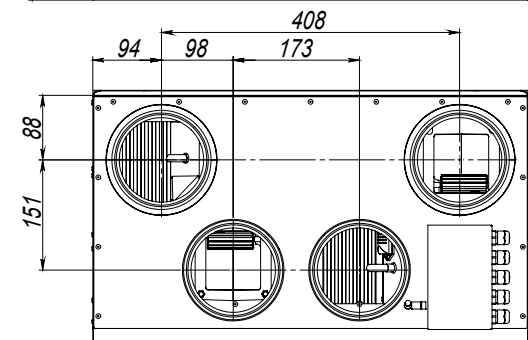
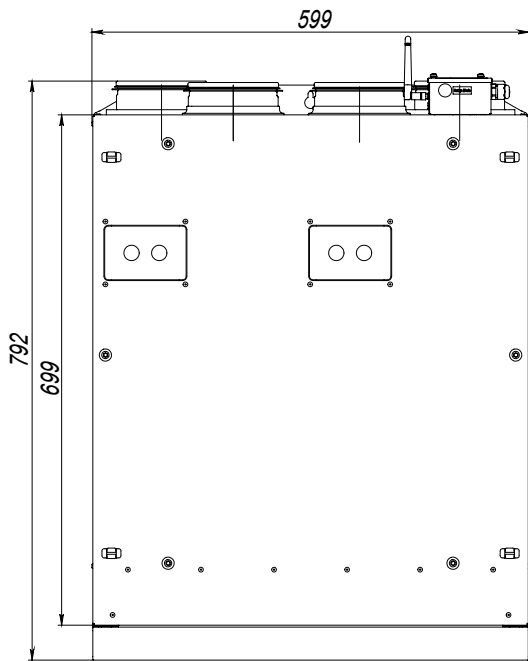
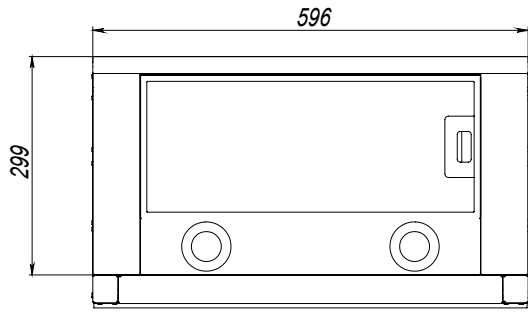

DESIGN AND OPERATING PRINCIPLE

The principle of operation of the unit is as follows: warm exhaust air from the room is drawn into the unit via the air ducts, where it is filtered. The air then passes through a rotary heat exchanger and is removed outside through air ducts by an exhaust fan.

The clean, cool air from the outside is supplied via the air ducts to the unit's supply filter, where it is filtered. The air then passes through a rotary heat exchanger and an electric heater (for VUTR 202 VEK(S) EC), where it is heated, and is then supplied into the room through the air ducts by a supply fan.

The rotary heat exchanger exchanges the heat energy of the warm exhaust air extracted from the room with clean, cool air supplied from the street. Heat exchange minimises heat loss and operating costs for heating the building in the cold season and cooling it in the warm season.

The cooker hood is equipped with an air damper that closes the exhaust air duct when the unit is not in use.

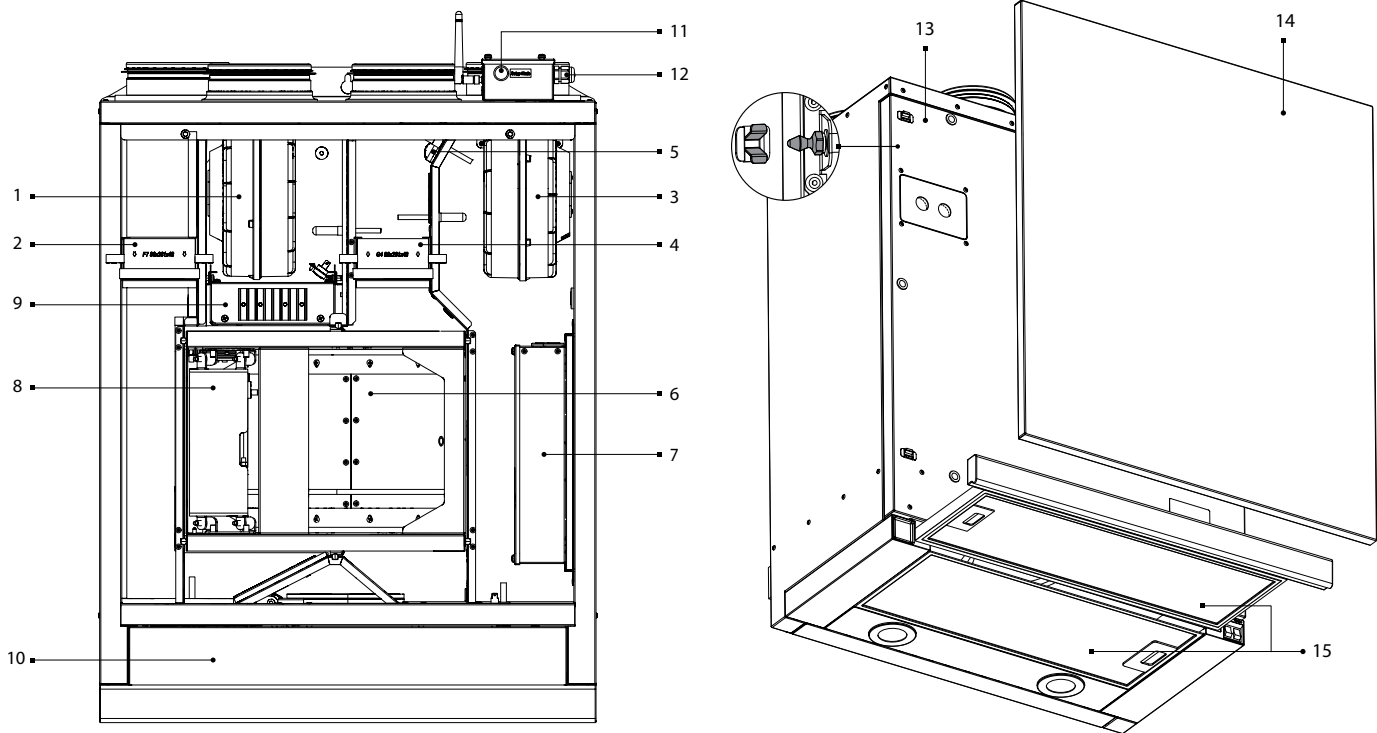

1 — supply fan; 2 — supply filter; 3 — exhaust fan; 4 — exhaust filter; 5 — humidity sensor (optional); 6 — rotary heat exchanger; 7 — control unit; 8 — rotary heat exchanger drive; 9 — electric heater (models equipped with a heater); 10 — cooker hood; 11 — Setup Mode button; 12 — airtight lead-ins; 13 — service panel, 14 — decorative panel (accessory, not included in the delivery set); 15 — cooker hood filters.

VUTR 202 V(E)K(S) EC L

VUTR 202 V(E)K(S) EC R

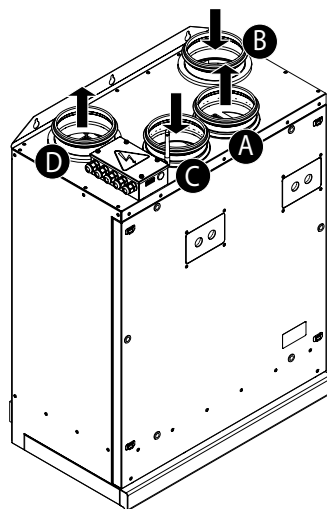
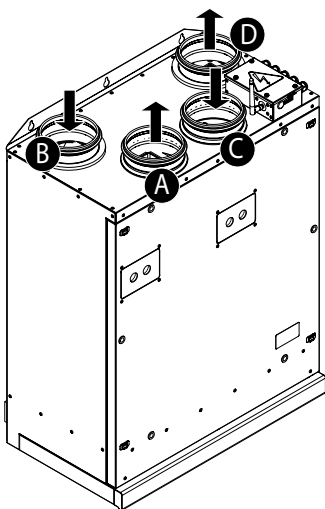

A – Supply air;
 B – Intake air;
 C – Extract air;
 D – Exhaust air.

MOUNTING AND SET-UP



READ THE USER'S MANUAL BEFORE INSTALLING THE UNIT



THE UNIT MUST BE MOUNTED BY A QUALIFIED EXPERT ONLY, PROPERLY TRAINED AND HAVING THE REQUIRED TOOLS AND MATERIALS.

The unit must be mounted so that it is easily accessible for maintenance and repair. The minimum recommended distances between the unit and walls are shown in the figure below.

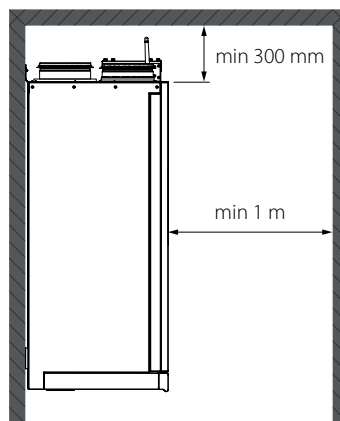

To attain the best performance of the unit and to minimise turbulence-induced air pressure losses connect straight air duct sections to the unit spigots.

The minimum straight air duct length is equal to 1 air duct diameter on intake side and 3 air duct diameters on outlet side.

The air ducts must be slid onto the flanges of the unit as far as they will go. Flexible air ducts must be rigidly secured with a metal worm clamp.

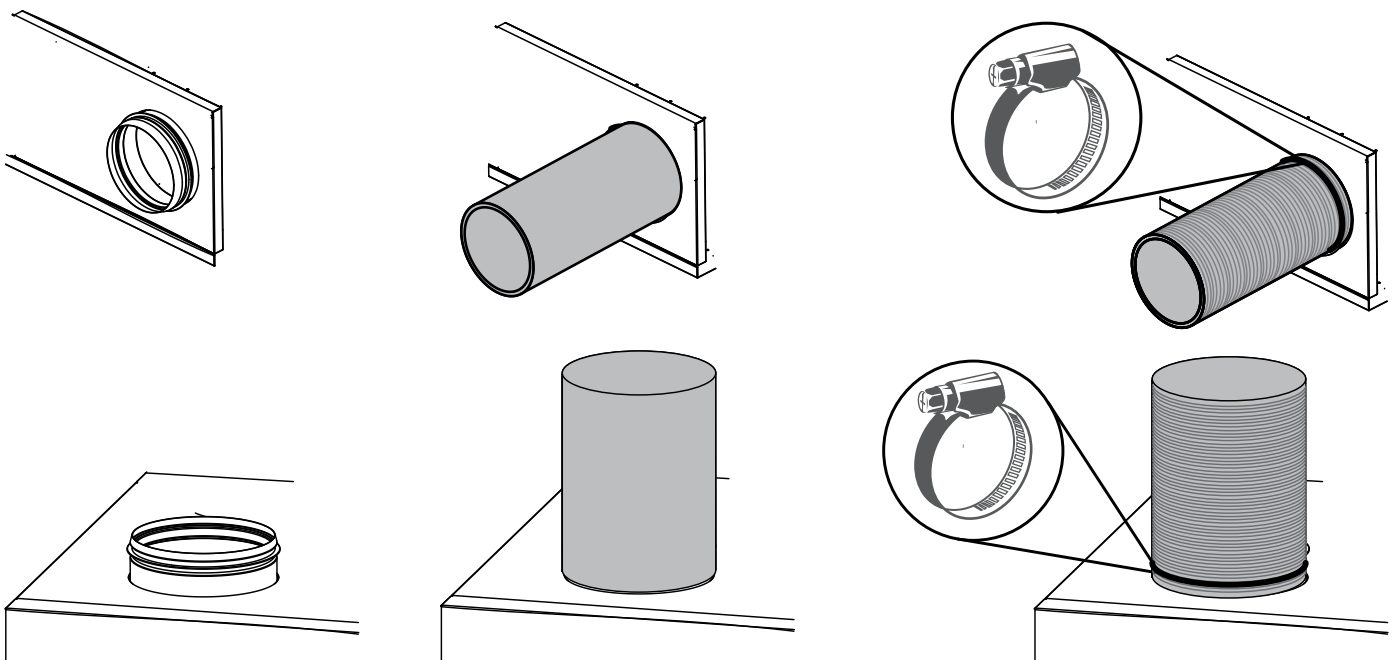

If there are no air ducts or the air ducts are short, it is necessary to protect internal unit parts from ingress of foreign objects at one or more unit spigots. To prevent uncontrollable access to the fan the spigots may be covered with a protecting grille or other protecting device with mesh width not more than 12.5 mm.

The wall on which the unit is to be mounted must be level. Mounting the unit on an uneven surface will cause the unit casing to become skewed and may prevent proper operation.

The unit is designed for wall mounting with three screws and dowels (not included in the delivery set). While choosing fasteners consider the material of the mounting surface as well as the weigh of the fan, refer to Technical Data section. Fasteners for unit mounting should be selected by the service technician.

HUMIDITY SENSOR INSTALLATION

The humidity sensor is not included in the delivery set and must be ordered separately. The humidity sensor must be installed before the unit is mounted.

Humidity sensor installation sequence:

1. Remove the decorative (if any) and service panels;
2. Disconnect the ground wire from the service panel;
3. Secure the humidity sensor to the exhaust duct wall.
4. Connect the connector to the sensor.

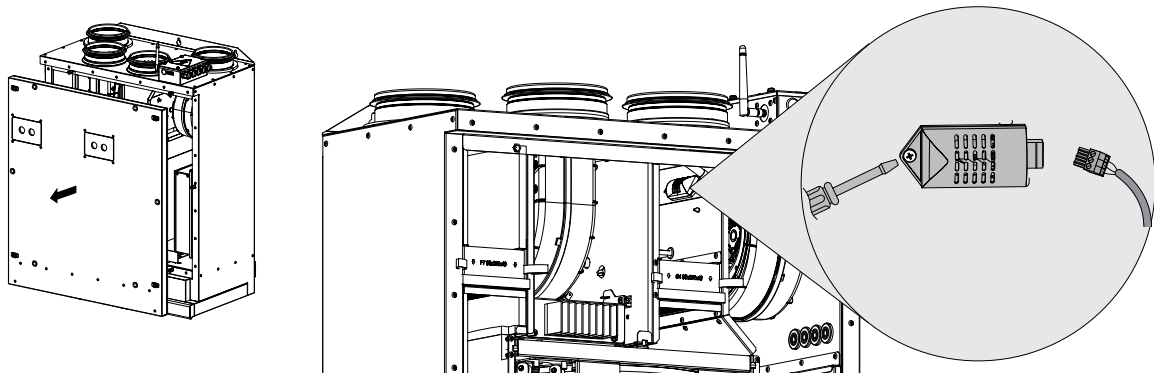

UNIT INSTALLATION

Mark and drill the mounting holes, screw in the screws, and hang the unit. Be careful when hanging the unit. Before use, ensure that the unit is securely mounted.

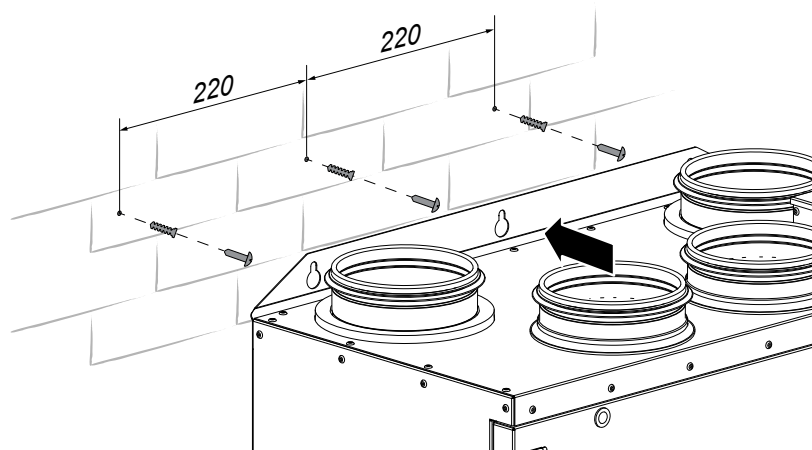

CONNECTION TO POWER MAINS



ANY TAMPERING WITH THE INTERNAL CONNECTIONS IS PROHIBITED AND WILL VOID THE WARRANTY.

- The unit is designed to be connected to the mains in accordance with the wiring diagram.
- The unit must be connected to power mains using insulated electric conductors (cables, wires). The actual wire cross section selection must be based on the maximum load current, maximum conductor temperature depending in the wire type, insulation, length and installation method.
- The external power input must be equipped with an automatic circuit breaker built into the stationary wiring to open the electric circuit in case of overload or short-circuit. The circuit breaker installation place must provide quick access for emergency shutdown of the unit. The trip current of the automatic circuit breaker must exceed the maximum current consumption of the unit (refer to the technical data table). The recommended trip current of the circuit breaker is the next current in the standard trip current row following the maximum current of the connected unit. The circuit breaker is not included in the delivery set.

ACCESS TO THE TERMINAL BLOCK

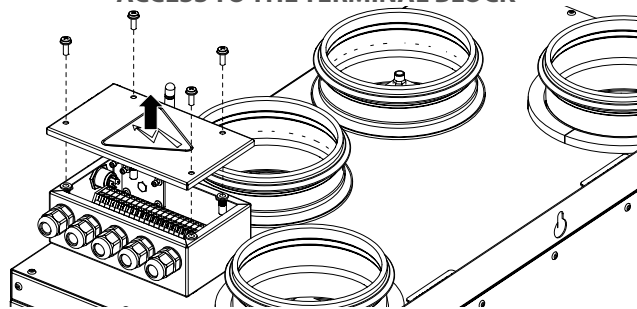

EXTERNAL CONNECTIONS DIAGRAM

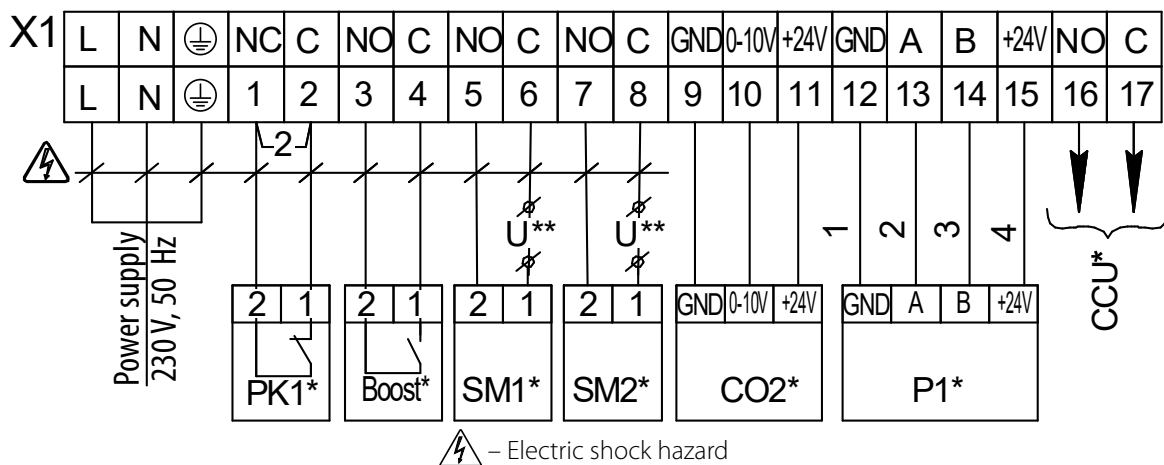

Designations	Name	Contact type	Cable type	Note
SM1*	Supply air damper drive	NO	2 x 0,75 mm ²	3A, 30DC/~250 AC
SM2 *	Exhaust air damper drive	NO		3A, 30DC/~250 AC
PK1*	Fire alarm panel	NC		Remove the jumper 2
CCU*	Cooler control	NO		3A, 30DC
P1*	External control panel		4 x 0,5 mm ²	
Boost*	Boost mode on/off contacts	NO	2 x 0,75 mm ²	
CO2*	External CO ₂ sensor		3 x 0,25 mm ²	

*The product is not included in the delivery set.

**Supply voltage of the external dampers SM1, SM2 is selected depending on the type of dampers.

TECHNICAL MAINTENANCE



DISCONNECT THE UNIT FROM POWER SUPPLY BEFORE ANY MAINTENANCE OPERATIONS!

Maintenance operations of the unit are required 3-4 times per year. Maintenance includes general cleaning of the unit and the following operations:

1. Filter maintenance.

Clogged filters increase air resistance in the system and reduce supply air volume.

Clean the filters as required, but not less than 3-4 times per year. Upon elapsing of 3000 operating hours the controller reminds about the need to replace or clean the filters. In this case clean or replace the filters and reset the filter timer. Filter cleaning with a vacuum cleaner is allowed. After two consecutive cleanings the filters must be replaced. For new filters please contact to the unit Seller.

Steps for removal of the filters:

1. Disconnect the unit from power supply.
2. Remove the decorative (if any) and service panels;
3. Disconnect the ground wire from the service panel;
4. Remove the filters by pulling them towards you.

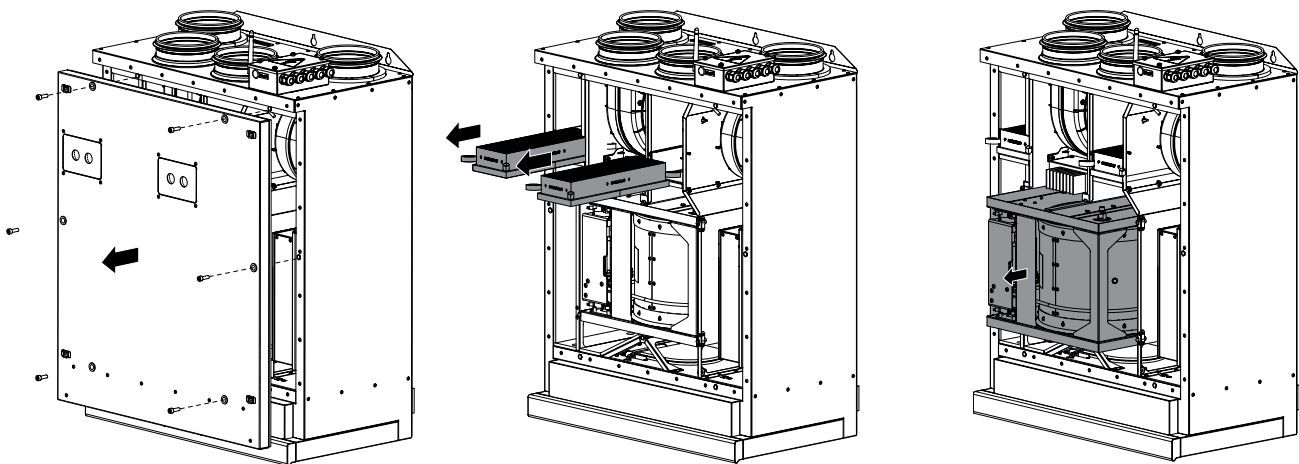

2. Heat exchanger maintenance (once per year).

Some dust may accumulate on the heat exchanger even in case of regular maintenance of the filters. Regular cleaning of the heat exchanger is required to maintain high heat recovery efficiency. To clean the heat exchanger pull it out of the unit and clean it with compressed air or a vacuum cleaner. After cleaning install the heat exchanger back in the unit.

Steps for removal of the heat exchanger:

1. Disconnect the unit from power supply.
2. Remove the decorative (if any) and service panels;
3. Disconnect the ground wire from the service panel;
4. Disconnect the heat exchanger and remove it by pulling it towards you.

3. Fan maintenance (once a year).

Even in case of regular maintenance of the filters, some dust may accumulate inside the fans and reduce the fan performance and supply air flow.

Clean the fans with a soft cloth or brush.

Do not use water, aggressive solvents or sharp objects as they may damage the impeller.

4. Maintenance of air intake devices (twice per year).

The supply grille may get clogged with leaves and other objects, which reduces the unit performance and supply air delivery. Check the supply grille twice per year and clean it as required.

5. Air duct system maintenance (every 5 years).

Even regular fulfilling of all the maintenance operations described above may not completely prevent dust accumulation in the air ducts, which reduces the unit performance.

Duct maintenance means regular cleaning or replacement.

6. Maintenance of the cooker hood filters.

The cooker hood's aluminium filters, designed to trap grease and dust from the exhaust air, become clogged over time and need to be cleaned. To clean the filter, soak it in hot water and detergent every 1.5-2 months. Filter performance is not affected by changes in colour after washing. To remove the aluminium filter, press the spring-loaded latch and pull it out. Then pull out the sliding panel with the second filter and remove it. To install the filters, follow the same steps in reverse order.

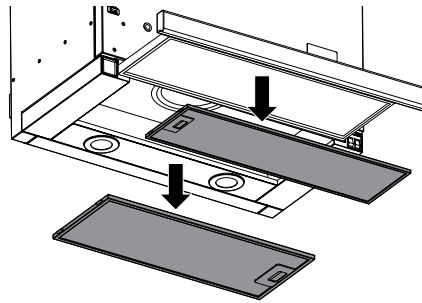

TROUBLESHOOTING

POSSIBLE REASONS AND TROUBLESHOOTING

Trouble	Possible reasons	Troubleshooting
The fan(s) do(es) not get started during activation of the unit.	No power supply.	Make sure the power supply line is connected correct. Otherwise troubleshoot a connection error.
	Motor or impeller clogging.	Turn the unit off. Troubleshoot the fan clogging. Clean the blades. Restart the unit.
Automatic circuit breaker tripping after the unit start-up.	Overcurrent as a result of short circuit in the electric circuit.	Turn the unit off. Contact the unit Seller.
Low air flow.	Low set fan speed.	Set higher speed.
	Clogged filters, fans or heat exchanger.	Clean or replace the filters. Clean the fans and the heat exchanger.
	Clogged or damaged air ducts, diffusers, louver shutters, grilles or other ventilation system components.	Clean or replace the air ducts, diffusers, louver shutters, grilles or other ventilation system components.
Low supply air temperature.	Clogged extract filter.	Clean or replace the extract filter.
	The unit operates in cooling mode.	Check the unit operating mode settings.
Noise, vibration.	Clogged impeller or impellers.	Clean the impeller or impellers.
	Loose screw connection in the fan or in the casing.	Tighten the screws of the fans or the casing against stop.
	No anti-vibration connectors on the connection spigots.	Install the rubber anti-vibration connectors.

Make sure that the U-trap is filled with water and the drain pipes are frost protected.

If troubleshooting steps have failed, contact the Seller of the product.

In case of faults not described in the table, contact the Seller for further information.

STORAGE AND TRANSPORTATION REGULATIONS

- Store the unit in the manufacturer's original packaging box in a dry closed ventilated premise with temperature range +5...+40 °C and relative humidity up to 70 %.
- Storage environment must not contain aggressive vapors and chemical mixtures provoking corrosion, insulation, and sealing deformation.
- Use suitable hoist machinery for handling and storage operations to prevent possible damage to the unit.
- Follow the handling requirements applicable for the particular type of cargo.
- The unit can be carried in the original packaging by any mode of transport provided proper protection against precipitation and mechanical damage. The unit must be transported only in the working position.
- Avoid sharp blows, scratches, or rough handling during loading and unloading.
- Prior to the initial power-up after transportation at low temperatures, allow the unit to warm up at operating temperature for at least 3-4 hours.

MANUFACTURER'S WARRANTY

The product is in compliance with EU norms and standards on low voltage guidelines and electromagnetic compatibility. We hereby declare that the product complies with the provisions of Electromagnetic Compatibility (EMC) Directive 2014/30/EU of the European Parliament and of the Council, Low Voltage Directive (LVD) 2014/35/EU of the European Parliament and of the Council and CE-marking Council Directive 93/68/EEC. This certificate is issued following test carried out on samples of the product referred to above.

The manufacturer hereby warrants normal operation of the unit for 24 months after the retail sale date provided the user's observance of the transportation, storage, installation, and operation regulations. Should any malfunctions occur in the course of the unit operation through the Manufacturer's fault during the guaranteed period of operation, the user is entitled to get all the faults eliminated by the manufacturer by means of warranty repair at the factory free of charge. The warranty repair includes work specific to elimination of faults in the unit operation to ensure its intended use by the user within the guaranteed period of operation. The faults are eliminated by means of replacement or repair of the unit components or a specific part of such unit component.

The warranty repair does not include:

- routine technical maintenance
- unit installation/dismantling
- unit setup

To benefit from warranty repair, the user must provide the unit, the user's manual with the purchase date stamp, and the payment paperwork certifying the purchase. The unit model must comply with the one stated in the user's manual. Contact the Seller for warranty service.

The manufacturer's warranty does not apply to the following cases:

- User's failure to submit the unit with the entire delivery package as stated in the user's manual including submission with missing component parts previously dismantled by the user.
- Mismatch of the unit model and the brand name with the information stated on the unit packaging and in the user's manual.
- User's failure to ensure timely technical maintenance of the unit.
- External damage to the unit casing (excluding external modifications as required for installation) and internal components caused by the user.
- Redesign or engineering changes to the unit.
- Replacement and use of any assemblies, parts and components not approved by the manufacturer.
- Unit misuse.
- Violation of the unit installation regulations by the user.
- Violation of the unit control regulations by the user.
- Unit connection to power mains with a voltage different from the one stated in the user's manual.
- Unit breakdown due to voltage surges in power mains.
- Discretionary repair of the unit by the user.
- Unit repair by any persons without the manufacturer's authorization.
- Expiration of the unit warranty period.
- Violation of the unit transportation regulations by the user.
- Violation of the unit storage regulations by the user.
- Wrongful actions against the unit committed by third parties.
- Unit breakdown due to circumstances of insuperable force (fire, flood, earthquake, war, hostilities of any kind, blockades).
- Missing seals if provided by the user's manual.
- Failure to submit the user's manual with the unit purchase date stamp.
- Missing payment paperwork certifying the unit purchase.



FOLLOWING THE REGULATIONS STIPULATED HEREIN WILL ENSURE A LONG AND TROUBLE-FREE OPERATION OF THE UNIT



USER'S WARRANTY CLAIMS SHALL BE SUBJECT TO REVIEW ONLY UPON PRESENTATION OF THE UNIT, THE PAYMENT DOCUMENT AND THE USER'S MANUAL WITH THE PURCHASE DATE STAMP

CERTIFICATE OF ACCEPTANCE

Unit Type	Single-room air handling unit with heat recovery
Model	
Serial Number	
Manufacture Date	
Quality Inspector's Stamp	

SELLER INFORMATION

Seller	
Address	
Phone Number	
E-mail	
Purchase Date	
This is to certify acceptance of the complete unit delivery with the user's manual. The warranty terms are acknowledged and accepted.	
Customer's Signature	

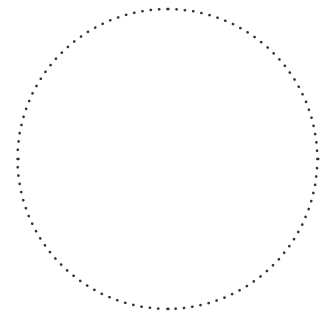

Seller's Stamp

INSTALLATION CERTIFICATE

The _____ unit is installed pursuant to the requirements stated in the present user's manual.	
Company name	
Address	
Phone Number	
Installation Technician's Full Name	
Installation Date:	Signature:
The unit has been installed in accordance with the provisions of all the applicable local and national construction, electrical and technical codes and standards. The unit operates normally as intended by the manufacturer.	
Signature:	

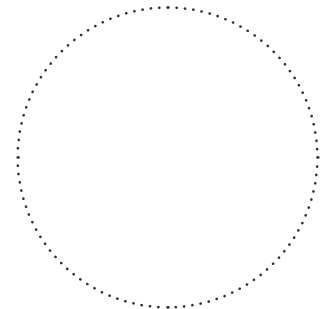

Installation Stamp

WARRANTY CARD

Unit Type	Single-room air handling unit with heat recovery
Model	
Serial Number	
Manufacture Date	
Purchase Date	
Warranty Period	
Seller	

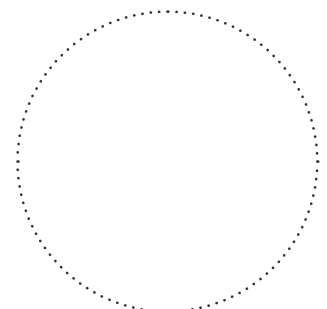

Seller's Stamp

