

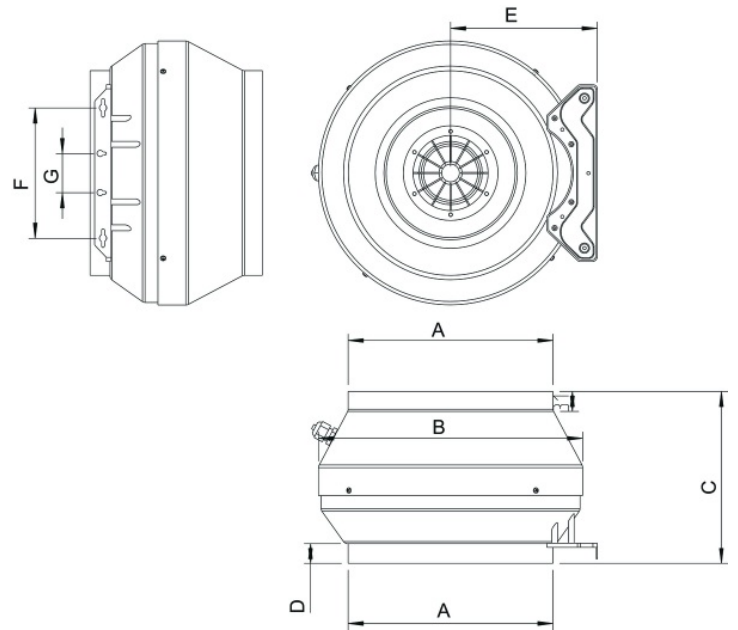

Technical parameters

Nominal data	
Voltage (nominal)	400 V
Frequency	50 Hz
Phases	3~
Input power	84 W
Input current	0.2 A
Impeller speed	1,385 rpm
Air flow	max 1,120 m ³ /h
Temperature of transported air	max 40 °C
Max temperature of transported air, when speed controlled	40 °C
Sound data	
Sound pressure level at 3m (20m ² Sabin)	41 dB(A)
Protection/Classification	
Enclosure class, motor	IP44
Insulation class	B
Explosion proof marking	II 2G Ex h IIB+H2 T3 Gb
Certificate	TPS 20 ATEX 085751 0009 X
Ambient and duct temperature	
Ambient and duct temperature	-20 to 40 °C
Dimensions and weights	
Duct dimension; Circular, inlet	315 mm
Duct dimension; Circular, outlet	315 mm
Weight	7 kg
Others	
Duct connection type	Circular
Color name, casing	Black
Motor type	AC

Dimension



	øA	øB	C	D	E	F	G
RVK-EX 315	314	405	264	30,5	225	200	60

Wiring

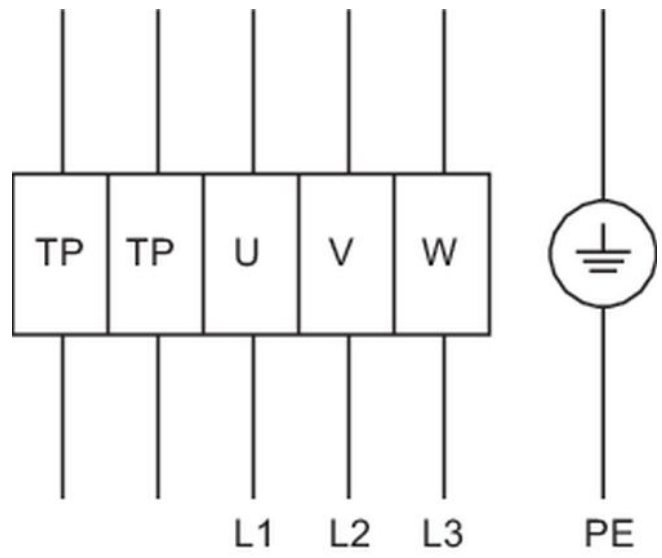

U	braun	brown	brun
V	blau oder grau	blue or grey	bleu or gris
W	schwarz	black	noir
TP	weiß	white	blanc

Performance curve

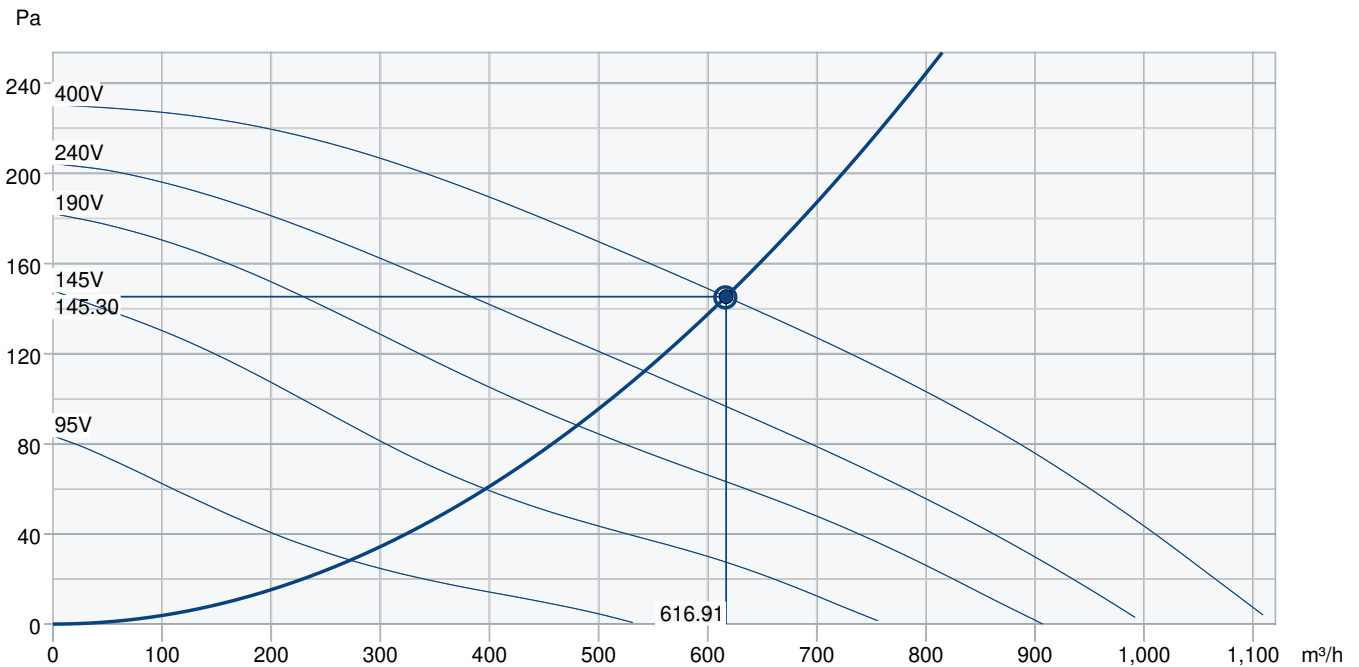

Hydraulic data										
Required air flow										616 m³/h
Required static pressure										145 Pa
Working air flow										617 m³/h
Working static pressure										145 Pa
Air density										1.204 kg/m³
Power										83.6 W
Fan control - RPM										1,386 rpm
Current										0.20 A
SFP										0.14 W/m³/h
Control voltage										400.0 V
Supply voltage										400 V

Sound power level		63	125	250	500	1k	2k	4k	8k	Total
Inlet	dB(A)	45	62	62	60	58	54	54	45	67
Outlet	dB(A)	50	62	62	59	60	57	55	45	68
Surrounding	dB(A)	18	27	36	44	44	39	34	25	48
Sound pressure level at 3m (20m² Sabine)	dB(A)	-	-	-	-	-	-	-	-	41
Sound pressure level at 3m free field	dB(A)	-	-	-	-	-	-	-	-	27

Accessories

Accessories

- | | |
|---------------------------------------|---------------------------------------|
| R-DK4 KT Transformer (302568) (6051) | RTRD 2 Speed Cont. Systemair (5941) |
| RTRDU 2 Speed contr. Systemair (5945) | SG 315 Protection guard (5611) |
| U-EK230E Motor protection (30199) | REV-3POL/ATEX-11kW R/Y (36414) |
| FK 315 Fast clamp (1613) | Ex e-Terminal box 1,5/6mm² 32A (2704) |

Documents

- imo_fans_atex_en_008
- PTB_08_ATEX_3060_TRANSLATION.PDF
- TPS_20_ATEX_085751_0009_X_EN.PDF
- UPDATE_PTB_08_ATEX_3060_3061_3062.PDF
- EU_DECLARATION_OF_CONFORMITY_ALL_009_314830.PDF