



NEW

VENTO Expert A50-1 W

Air capacity – up to 50 m³/h

Heat recovery efficiency – up to 97 %

Use

- ❑ Arrangement of efficient energy-saving, supply and exhaust, single-room ventilation in flats, houses, cottages, social and commercial premises.
- ❑ Reducing heat losses caused by ventilation due to heat recovery.
- ❑ Humidity balance and regulated air exchange create individually controlled microclimate.
- ❑ Wi-Fi communication between several single-room ventilation units for coordinated operation.
- ❑ Controlled by Android or iOS smartphone or tablet.

Design

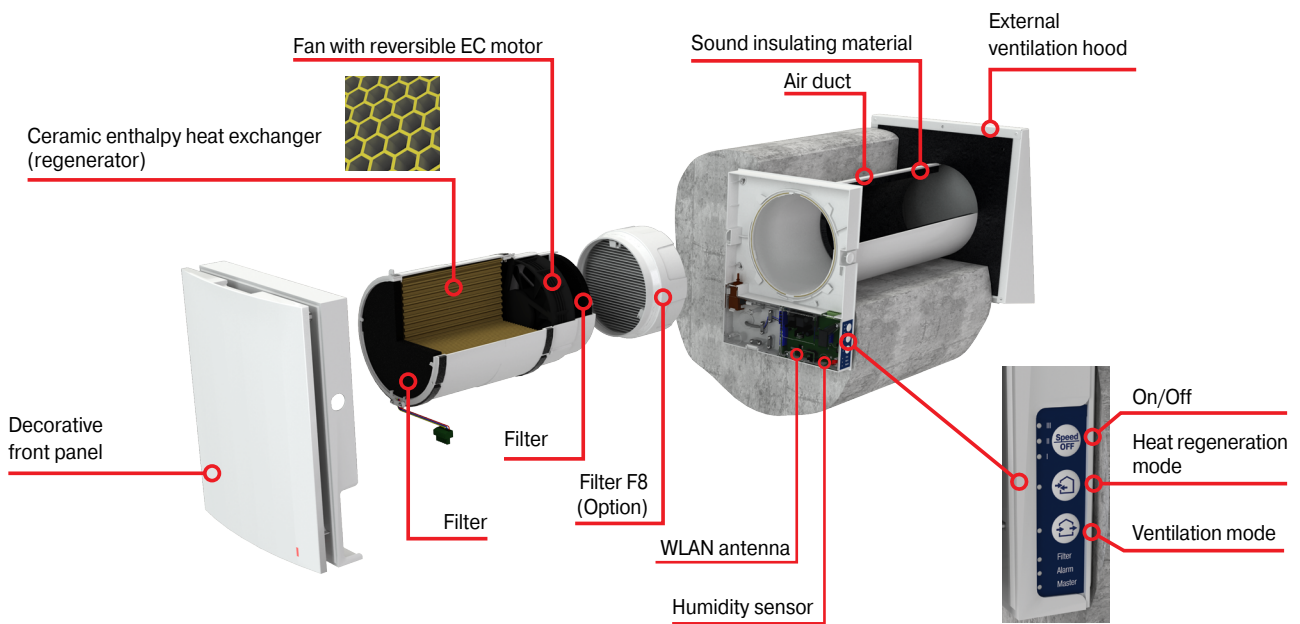

Easy maintenance. Indoor unit is opened by pressing the latches on both sides.



Integrated automatic air shutters prevent air back drafting.



The specially designed front panel can be closed manually to ensure 100% air tightness and protect against wind impact.

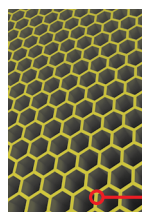

One of the best regeneration efficiency on the market due to innovative hexagonal structure of the heat exchanger cells.



- Speed
- Ventilation mode
- Heat regeneration mode
- High timer: low speed for 8 hours
- Party timer: high speed for 4 hours



Built-in Wi-Fi for wireless communication between units and Android or iOS device control

Unit operating logic in winter period

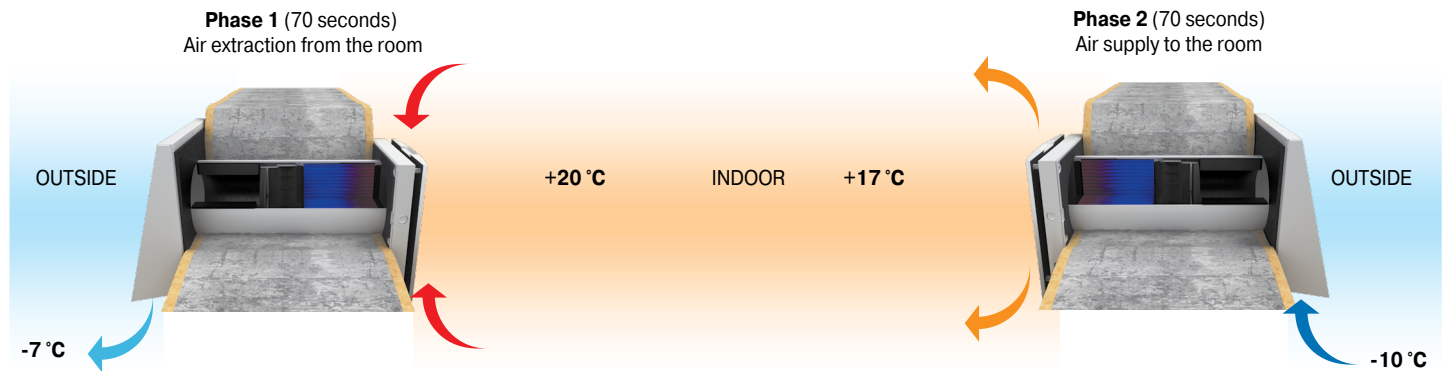

- Warm stale air is extracted from the premise, flows through the ceramic regenerator and transfers its heat energy and moisture to it.
- As the ceramic regenerator gets warmed up, the unit switches to the supply mode.
- Clean cold intake air flows through the regenerator and absorbs accumulated heat and humidity.
- When the ceramic regenerator is cooled down, the unit switches to the extract air mode.

Control

- The units can be connected by Wi-Fi for synchronized operation.



The units can be connected by Wi-Fi. Blauberg Vento app for Android or iOS devices is available at Google Play and App Store.



The Vento Expert A50-1 W unit can be connected to a laptop for advanced settings:

- Master or slave
- Supply or exhaust operation in ventilation mode
- Connection through a Wi-Fi router or directly to a smartphone.



A humidity sensor is built into the unit



An external CO₂ sensor can be connected to the unit

HEAT RECOVERY SINGLE-ROOM UNITS

■ Mounting

- The unit is designed for through-the-wall installation inside a prepared hole in an outer wall of the building.
- The best ventilation solution is pairwise installation of reverse phase connected units. Some units ensure supply of fresh air to the room and the other units extract air from the premise. This way the most efficient balanced ventilation is arranged.

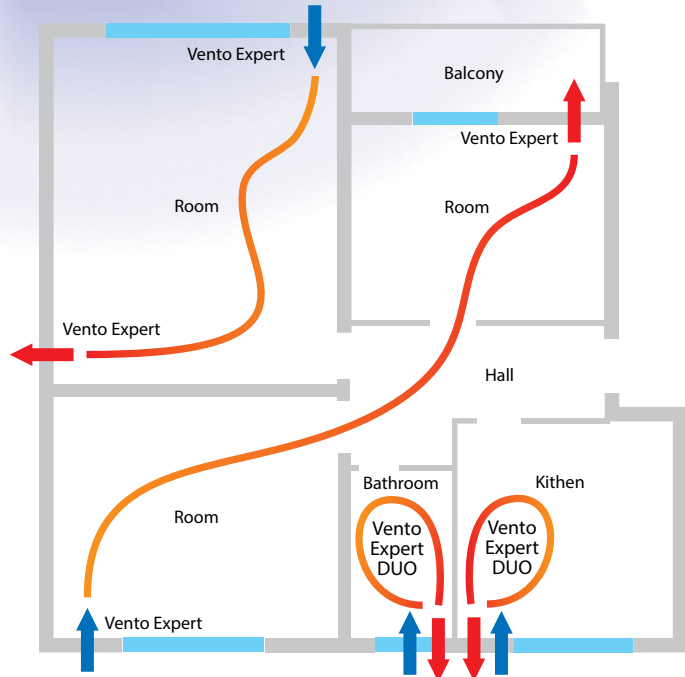

- In case of brand new construction, units are mounted in two stages:
 - **Pre-installation** at the stage of the indoor finishing and outer decorative wall finishing. It includes installation of an air duct, an outer ventilation hood and cable installation;
 - **Completion of the installation** before commissioning of a house. It includes installation of the indoor unit with controller and shutters, the cartridge, the regenerator, the fan and the filters.

■ Overall dimensions

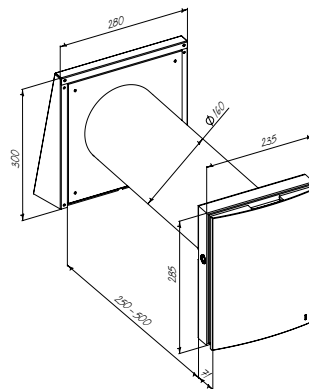

Vento Expert A50-1 W

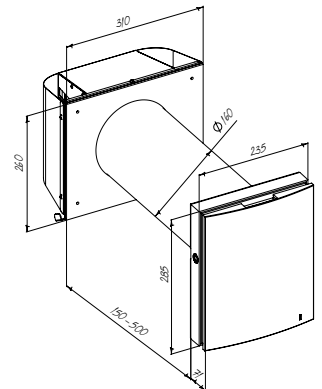

Vento Expert A50-1 S W
(for thin walls)

■ Technical data

Parameters	VENTO EXPERT A50-1 W / VENTO EXPERT A50-1 S W		
	1	2	3
Speed	1	2	3
Voltage / 50-60 Hz [V]	100-230		
Power [W]	4.45	5.08	7.06
Current [A]	0.035	0.040	0.059
RPM [min ⁻¹]	800	1300	1900
Air capacity in airing mode [m ³ /h]	15	30	50
Air capacity in heat regeneration mode [m ³ /h]	7.5	15	25
Filter	G3 (F8 PM2.5 > 75 % option)		
Temperature of transported air [°C]	-30...+50		
Noise level @ 1 m [dB(A)]	20	27	30
Noise level @ 3 m [dB(A)]	11	18	21
Outdoor sound pressure attenuation [dB(A)] in accordance with DIN EN 20140	42		
Regeneration efficiency [%] in accordance with DIBt LÜ-A 20	97	90	82
SEC class	A		
Ingress protection rating	IP24		

Angular mounting into a wall with standard thickness using
KIT BlauPlast white 160 /
KIT BlauPlast chrome 160

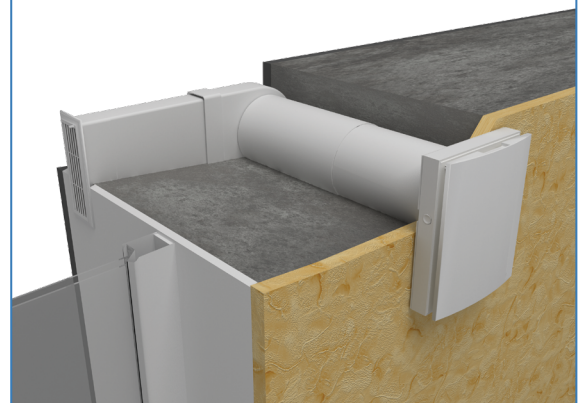

Accessories

Accessory name	Description
Pre-installation Kit VENTO Expert A50-1	Includes: <ul style="list-style-type: none"> • Air duct; • AH 160 outer ventilation hood; • Plastic foam plug.
Pre-installation Kit VENTO Expert A50-1 S	Includes: <ul style="list-style-type: none"> • Air duct; • AH-S 160 outer ventilation hood; • Plastic foam plug.
Completion Kit VENTO Expert A50-1	Includes: <ul style="list-style-type: none"> • Internal unit with a heat regenerator, a fan and G3 filters; • Indoor unit with a controller and shutters; • Remote control.
KIT BlauPlast white 160	Mounting kit for angular installation in walls with standard thickness
FP Vento Expert A50 G3	G3 filters (2 pcs.)
FP Vento Expert A50 F8	Includes: <ul style="list-style-type: none"> • Plastic frame (1 pc.) • G2 pre-filter (1 pc.) • F8 filter (1 pc.) Filtration rate PM2.5 99%. F8 filter reduces airflow of the unit down to 30 m ³ /h
FB Vento Expert	Remote control unit
CD-1	CO ₂ sensor with LED indication and On/Off button
CD-2	CO ₂ sensor